

## CHAPTER CONTENTS

Refer to this chapter for the following:

- Installation precautions and setup.
- Product Descriptions.
- Electrical Parameters.
- Mechanical Dimensions.
- Thermal considerations.
- GPS Antenna Module mounting.

### About the Oncore Antenna

The antenna module is housed in a custom styled, molded encasement that provides a rugged, durable protective cover, ready for exposure to the elements.

All of the antenna module's electrical circuitry and components are contained within the sealed antenna assembly. The major components include a low profile, microstrip patch antenna, a ceramic RF filter (i.e., preselector), and a signal preamplifier. The antenna module is designed and tuned to efficiently collect the L1 band signals transmitted from GPS satellites at a nominal frequency of 1575.42 MHz. Once collected, the signals are amplified and relayed to the Oncore receiver. Signal preamplification within the antenna module is made possible by external power supplied by the Oncore receiver. The antenna module nominally draws 20 mA of current at 5 Vdc, directly from the antenna connector on the Oncore receiver.

Various antenna module mounting options and assembly instructions are detailed in this chapter. The dimensions of the Motorola GPS antennas are shown in Figures 4.8 and 4.9.

## ANTENNA PLACEMENT

When mounting the antenna module, it is important to remember that GPS positioning performance will be most optimal when

- the antenna patch plane is level with the local geographic horizon, and
- the antenna has full view of the sky ensuring direct line-of-sight to all visible satellites overhead.

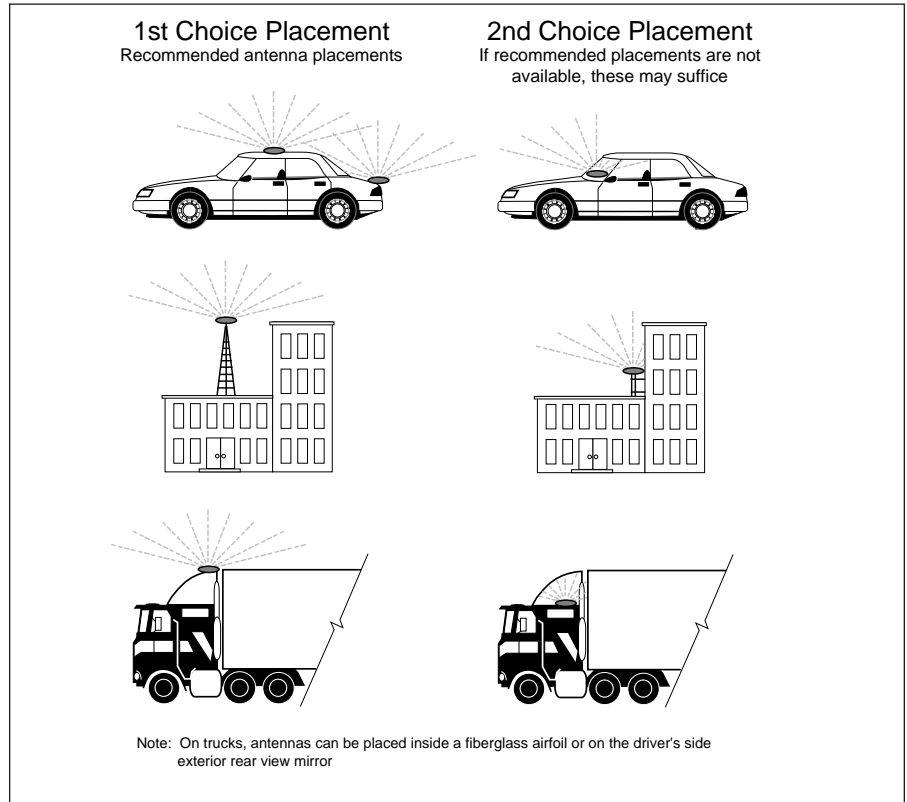

Figure 4.1: Proper Antenna Placement

## ANTENNA SYSTEM RF PARAMETERS CONSIDERATION

### Active Antenna & GT Oncore Receiver System

Both the gain and the noise of the overall system affect the performance of the A/D converter in a GPS receiver. The illustration below illustrates typical values for the Oncore family of GPS receivers when used with the Motorola antenna and standard RG-58/RG-174 type cable. The thresholds and ranges listed should be considered with a tolerance of 2 to 3 dB.

### System constraints:

1) The gain in decibels is cumulative through all stages (i.e.  $G = G1 + G2 + G3...$ ). The optimal gain of the antenna, cabling and any in-line amplifiers and splitters for the standard GT Oncore (model R3) is  $> 10$  but  $< 26$  dB. See the table below for other Oncore receiver models. The Oncore receiver may operate outside of the optimal gain range but performance will degrade. Therefore, Motorola does not recommend operating outside of the optimal gain range as indicated above and in the table below. For the system illustrated below, the external gain is approximately 22 dB in front of the receiver.

2) System noise (F) is not to exceed 4 dB. The cascaded system noise figure formula is

$$f = f_1 + \frac{f_2 - 1}{g^1} + \frac{f_3 - 1}{g^1 \cdot g^2} + \dots, \quad (= 1.9 \text{ dB for the system below})$$

where  $f_1$  is the noise figure for stage one and  $g_1$  is the gain for stage one. Note that all of these values are absolute. Recall the formula for converting absolute values to decibels:

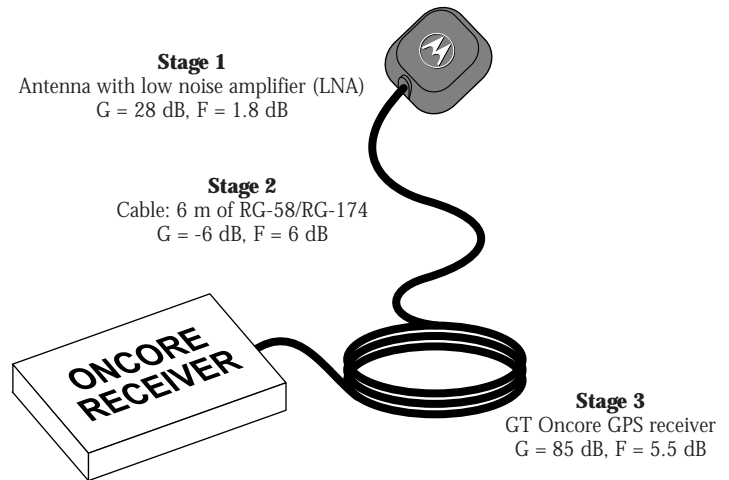

Figure 4.2

Table 4.1

Platform	Model	External Gain Range in dB <sup>1</sup>			RCVR	RCVR
		Minimum	Optimum	Maximum	Gain <sup>2</sup>	NF <sup>2</sup>
GT/UT	R1	10	22	35	85	5.5
GT	R3	10	22	26	85	5.5
GT w/(LNA)	R4	8	15	18	90	2.0
UT	R5	10	22	33	100	5.5
VP	B3	10	18	26	68	7.5

Notes:

1. All values indicated in this section are referenced over operating temperature
2. RCVR Gain and NF values are for receiver only and do not include antenna LNA or cable loss. The values indicated are referenced to ambient temperature

## RF Cable Length for AVL Applications

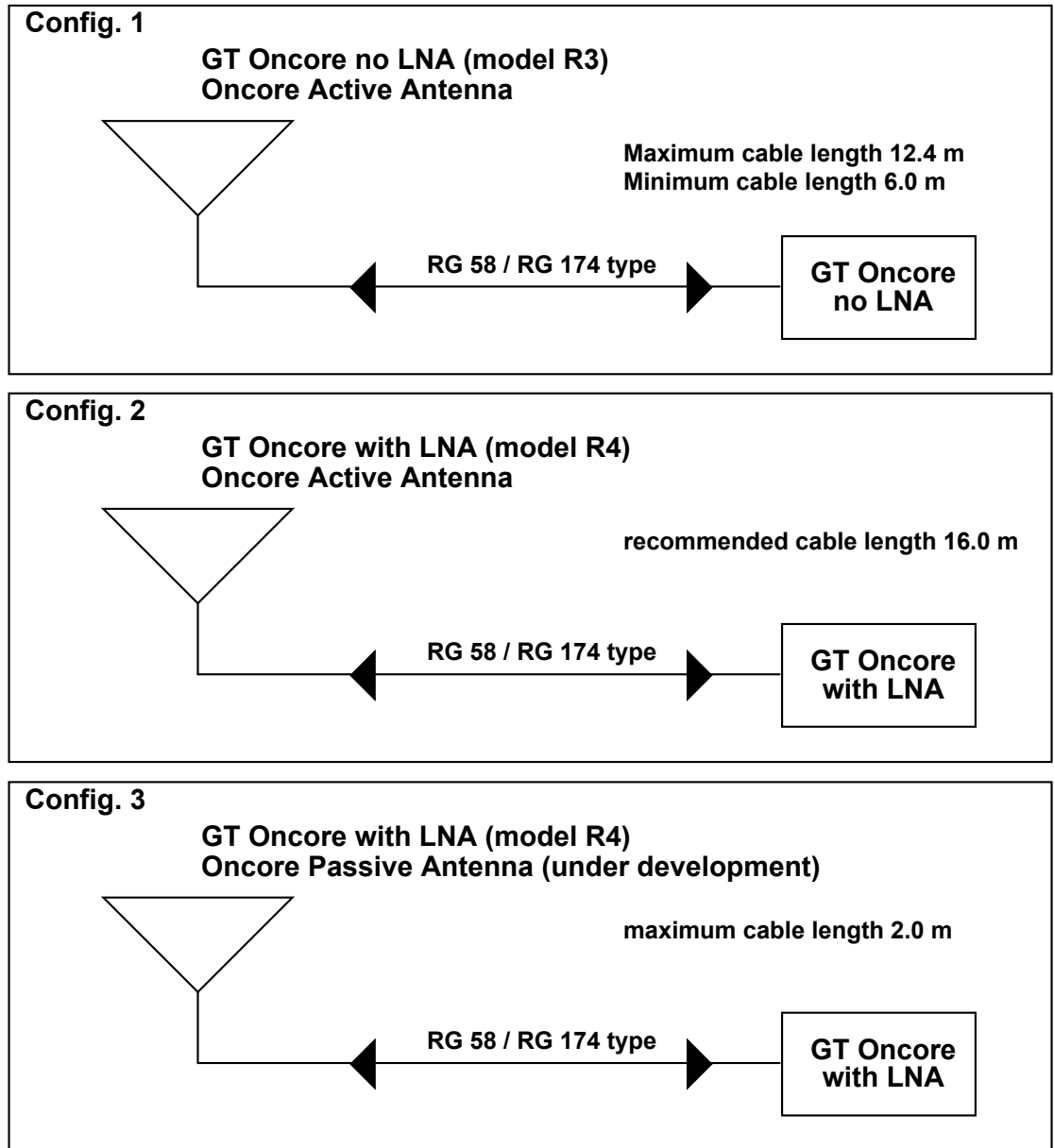

**Note:** All values on this page represent antenna performance at +25°C.

Figure 4.3

## Roof Mounted Low Loss Antenna Drop

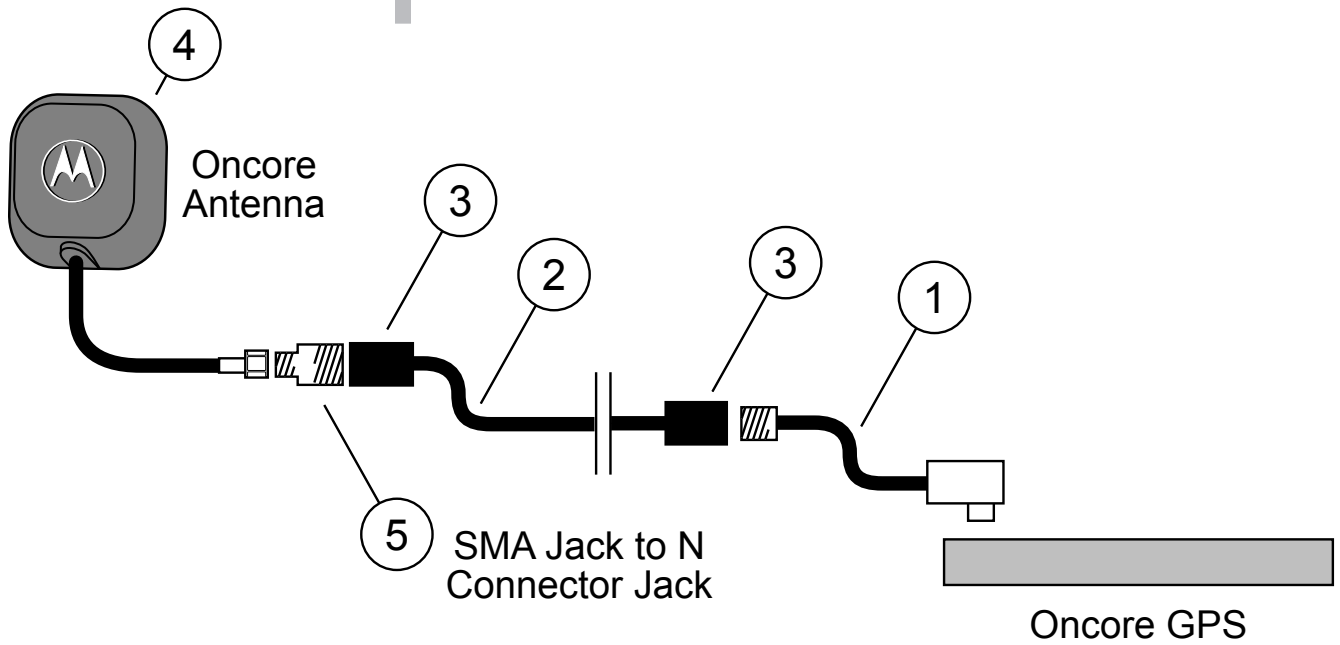

Figure 4.4

Table 4.2

Item	Description	Part No.	Supplier	Tel No.
1.	PCX-to-N RG-400 RF Cable, 1 foot	128BE27001	Phoenix	630-595-2300
2.	Heliax Low Loss RF Cable, 4dB/100 Feet	LDF4-50A	Phoenix	630-595-2300
3.	N Terminations	L44AW	Phoenix	630-595-2300
4 .	Active GPS Antenna 203mm Cable with SMA Connector	GCNAC1232A	Motorola	Contact Your Local Motorola GPS Distributor
5.	SMA Jack to N Connector Jack	2050110000G/C	Phoenix	630-595-2300

## Oncore GPS System Example

The graphic below illustrates an automotive application using the Motorola GT Oncore receiver mounted in the trunk and a GPS antenna mounted in the front dash area. Assumptions were made as to the connector (four Hirose GT-5 connections) and cable type (~6 meters of RG-174 type of cable) and the approximate associated losses (Conservative losses: 1 dB per meter for the cable and 0.5 dB per connector connection) at 1575 MHz. The GT Oncore (model R3) was designed to operate within an external gain range measured at the front of the receiver of greater than 10 but less than 26 dB. The gain at the front of the GT Oncore based on the information and assumptions above is well within the external gain range of the receiver. The calculated gain is approximately 20 dB (see system gain table below). Changing any of the above assumptions or system components illustrated below will necessitate the recalculation of the system gain. Refer to Section 5 of the Antenna System application note.

**Table 4.3: System Gain**

System Component	Gain (dB)
Antenna	~28
Connectors (4 ea.)	- 2
Cable	- 6
Gain at front end of receiver	20

**Note:** All values are at 25°C

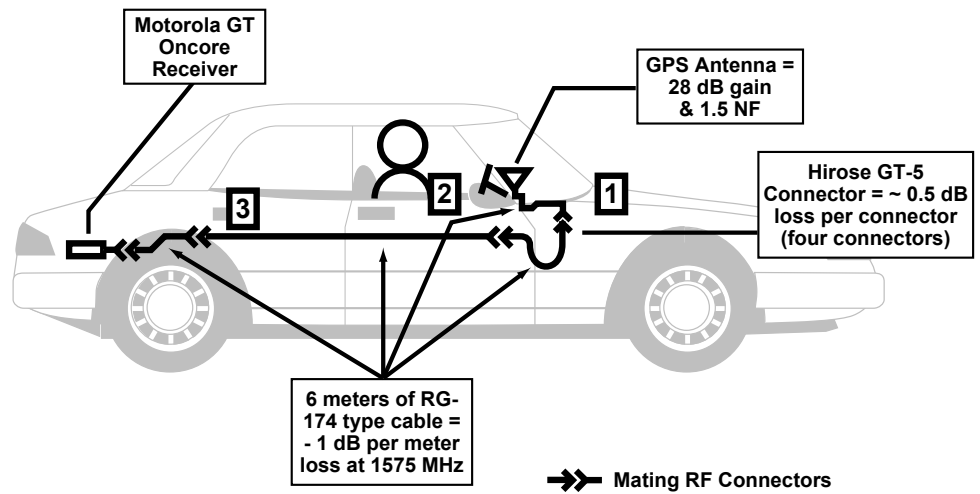

**Figure 4.5**

## ONCORE™ ACTIVE GPS ANTENNA

(GCNxxxxxxx)



*Figure 4.6: Antenna shown with 6m of cable and BNC connector*

### ANTENNA DESCRIPTION

The Oncore active GPS antenna is designed to operate with Motorola's successful family of Oncore GPS receivers, as well as many GPS receivers from other manufacturers. The antenna design reflects Motorola's high standard for performance when operating in foliage/urban canyon environments and in the presence of electromagnetic interference, while drawing only 20 milliamps at 5 Vdc, diplexed from the interconnecting coaxial cable.

The small footprint, low profile package and the shielded LNA (low noise amplifier) offers significantly enhanced performance while operating in a variety of GPS environments. Furthermore, magnetic and direct mount options make the antenna suitable for a number of different installation configurations. Moreover, the OEM or system integrator can count on signal gain and noise figure performance over an ambient operating temperature range which leads the industry.

## Active Antenna Specifications

Table 4.4: Motorola Part # GCNxxxxxxx Technical Characteristics

<b>General Characteristics</b>	Antenna Description	<ul style="list-style-type: none"> <li>• Low profile active microstrip patch antenna</li> <li>• Molded plastic radome</li> <li>• Electrically shielded LNA PWB assembly</li> </ul>
	Operating Frequency	<ul style="list-style-type: none"> <li>• L1 (1575.42 MHz, +/- 1.023 MHz)</li> </ul>
<b>Performance Characteristics</b>	Input Impedance	<ul style="list-style-type: none"> <li>• 50 Ohm</li> </ul>
	VSWR	<ul style="list-style-type: none"> <li>• 1.5 (typical) @ 1575.42 MHz</li> </ul>
	Bandwidth	<ul style="list-style-type: none"> <li>• 45 MHz @ 3 dB points (typical)</li> </ul>
	Polarization	<ul style="list-style-type: none"> <li>• Right hand circular</li> </ul>
	Azimuth Coverage	<ul style="list-style-type: none"> <li>• 360 degrees</li> </ul>
	Elevation Coverage	<ul style="list-style-type: none"> <li>• 0 degrees to 90 degrees</li> </ul>
	Gain Characteristics of Antenna Element	<ul style="list-style-type: none"> <li>• +2 dBic minimum at zenith (typical)</li> <li>• -10 dBic minimum at 0 degrees elevation (typical)</li> </ul>
	Filtering	<ul style="list-style-type: none"> <li>• -25 dB @ 1670 MHz (typical)</li> <li>• -25 dB @ 1480 MHz (typical)</li> </ul>
	LNA Gain	<ul style="list-style-type: none"> <li>• 24 dB (typical, including 6 dB cable loss)</li> </ul>
	Noise Figure	<ul style="list-style-type: none"> <li>• 1.8 dB (typical)</li> </ul>
<b>Electrical Characteristics</b>	Burnout Protection	<ul style="list-style-type: none"> <li>• Protected from damage by RF signals, when the power received by the antenna is no greater than +17 dBm absolute maximum</li> </ul>
	Dynamics	<ul style="list-style-type: none"> <li>• Vibration: 7.7G per Military Standard 810E Method 514.4</li> <li>• Shock: 100G (18 ms sawtooth) Military Standard 810E Method 516.4</li> </ul>
<b>Physical Characteristics</b>	Power Requirements	<ul style="list-style-type: none"> <li>• 5 ± 0.5 Vdc 50 mV p-p ripple (maximum)</li> </ul>
	Power Consumption	<ul style="list-style-type: none"> <li>• 20 mA @ 5 Vdc (typical)</li> </ul>
	Dimensions	<ul style="list-style-type: none"> <li>• 49.6 L x 43.0 W x 18.0 H mm</li> <li>• 33.3 L x 29.8 W x 8.8 H mm (Substrate w/shield)</li> </ul>
	Weight	<ul style="list-style-type: none"> <li>• &lt; 40 grams (housed assembly, less cable)</li> </ul>
	Cable Connector	<ul style="list-style-type: none"> <li>• 90 degree OSX/MCX (subminiature push on)</li> <li>• BNC</li> <li>• Call for other connector types (SMB, GT5...)</li> </ul>
	Antenna to Receiver Interconnection	<ul style="list-style-type: none"> <li>• Single RG-174U type coaxial cable 6 meters (20 ft.) long (10 dB maximum loss at 1575.42 Mhz)</li> <li>• Single RG-174U type coaxial cable 203 mm (8 in.) long</li> </ul>
	<b>Environmental Characteristics</b>	Operating Temperature Storage Temperature
Humidity		<ul style="list-style-type: none"> <li>• 95% noncondensing +30°C to +60°C</li> </ul>
UV Radiation		<ul style="list-style-type: none"> <li>• 1200 hrs. @ +63°C w/rain @ 12 min./hr.</li> </ul>
Salt Spray Test		<ul style="list-style-type: none"> <li>• Spray 5% NaCl solvent at +35°C for 320 hrs.</li> </ul>
<b>Miscellaneous</b>	Optional Features	<ul style="list-style-type: none"> <li>• Mounting options: <ul style="list-style-type: none"> <li>- Magnetic mount</li> <li>- Direct mount</li> </ul> </li> <li>• Substrate: patch antenna and shielded LNA on PWB with 6 meters of RG-316U type coaxial cable with 90 degree OSX/MCX connector</li> </ul>



## Antenna Gain Pattern

The sensitivity of an antenna as a function of elevation angle is represented by the gain pattern. Some directions are much more appropriate for signal reception than others, so the gain characteristics of an antenna play a significant role in the antenna's overall performance.

A cross-sectional view of the antenna gain pattern along a fixed azimuth (in a vertical cut) is displayed in the following figure. The gain pattern clearly indicates that the antenna is designed for full, upper hemispherical coverage, with the gain diminishing at low elevations. This cross-section is representative of any vertical cross-section over a 0 to 360 degree azimuth range and thus, the 3-dimensional gain pattern is a symmetric spheroidal surface. It is important to note that this gain pattern varies in elevation angle, but not in horizontal azimuth. This design is well-suited for many GPS applications, accommodating full sky coverage above the local horizon and minimizing ground-reflected multipath effects.

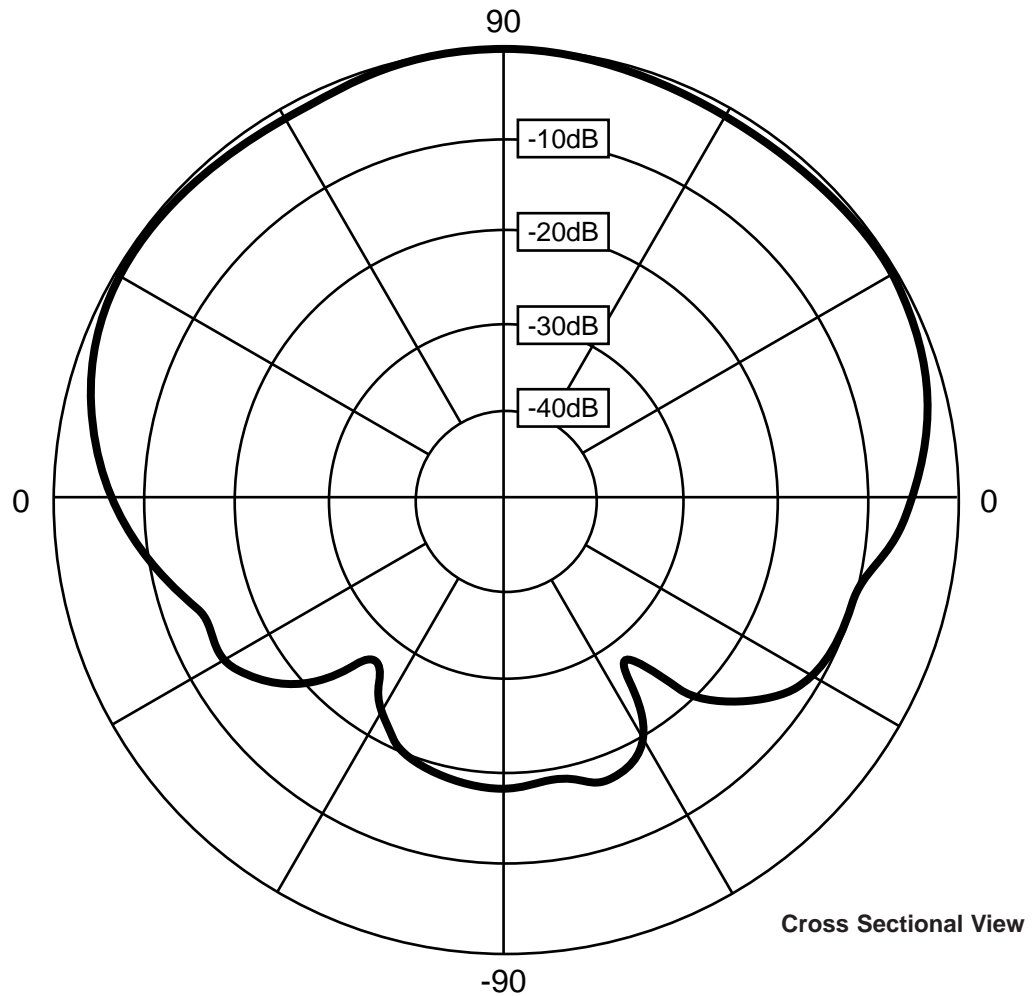

Figure 4.7: Typical Oncore Active Antenna Gain Pattern

## Mechanical Dimensions

All dimensions are in mm. For reference purposes only.

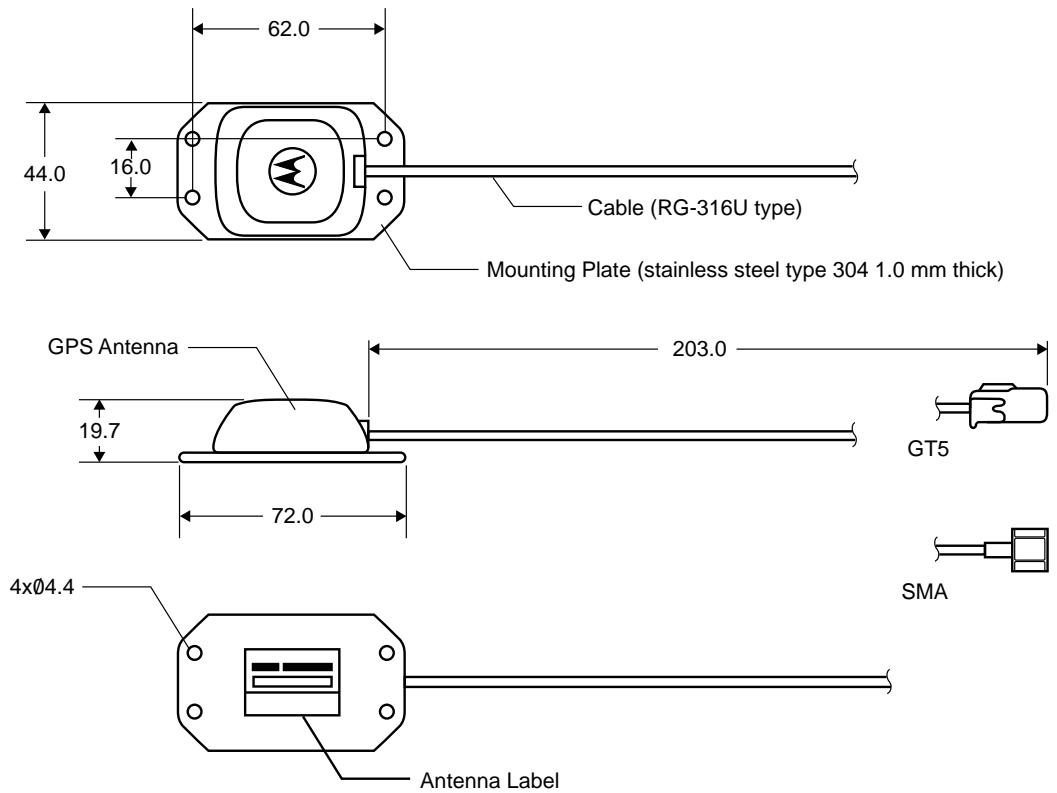
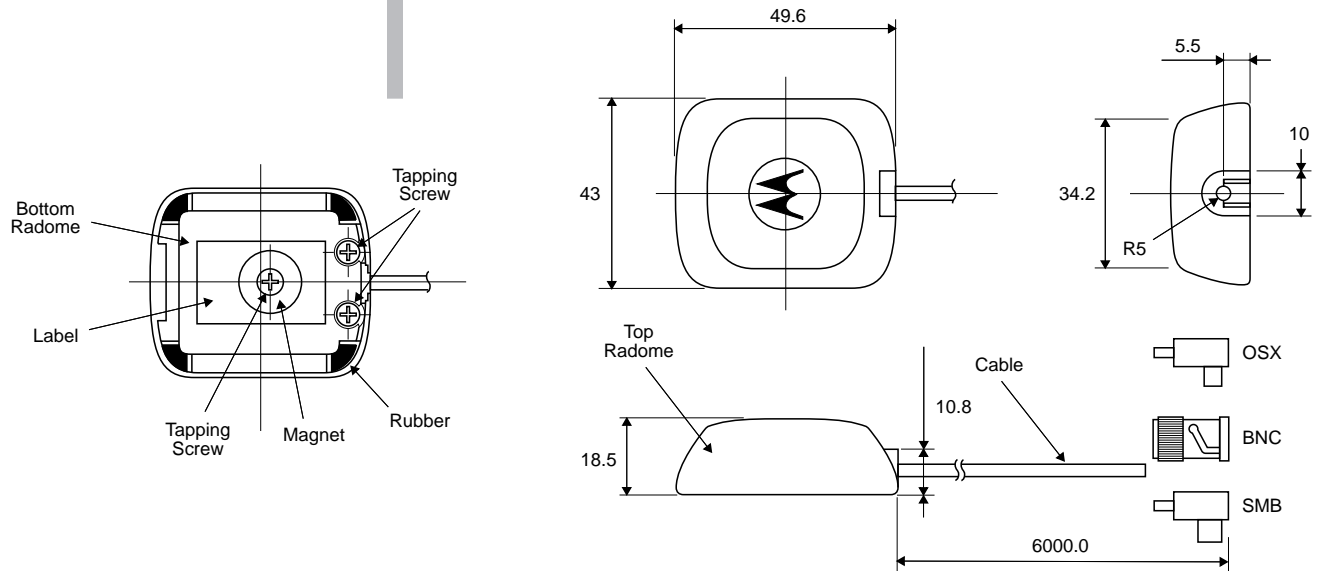

Figure 4.8: Magnetic Mount Configuration

Figure 4.9: Direct Mount Configuration

## **Mechanical Dimensions (continued)**

### **Notes:**

1. For the magnet type GPS antenna - the pull force of the GPS antenna, that is, straight upward vertical pull force is 1.5 kgf (minimum). Typically it is 1.8 kgf. This is a permanent/rare earth (Neodymium) type of magnet.
2. Direct mount mounting plate is attached to antenna base using commercial grade 3M VHB: 4914 acrylic foam tape. VHB: 4914 foam joining is double coated acrylic foam with acrylic pressure sensitive adhesive on both sides. It provides static shear, peel adhesion and resistance to solvents, UV light and elevated temperature. Combined with the screw as a secondary method for securing the mounting plate (bracket) to the antenna base, VHB: 4914 tape passed all the qualification tests (see Appendix B).
3. The minimum pull force that the cable/radome interface will withstand is 6 kg.

## **Recommended Mounting Hardware**

The recommended screws are 6-32 (English) or M3x0.6 (metric) for securing the mounting bracket onto the attached surface or plate. The suggested hole size is from 3.05 to 3.10 mm in diameter or as user feels appropriate.

## Motorola Part Numbers

Table 4.5 shows the various mounting styles and types of connectors that are offered. Also the Motorola model numbers and outline drawings are included in the table for reference.

**Table 4.5**

Motorola Model No:	Mounting Style	Length of Cable (mm)	Connector Style
GCNAC1242X*	Mounting Plate (Bracket)	203 ±5	Hirose GT5
GCNAC1232X	Mounting Plate (Bracket)	203 ±5	Straight SMA plug
GCNAC1121X	Magnet	6000 ±70	BNC plug
GCNAC1111X	Magnet	6000 ±70	Right angle OSX/MCX plug
GCNSU1110X* (Substrate)	N/A	6000 ±70	Right angle OSX/MCX plug

\* Special Order

**Note:** For Motorola model number GCNSU1110X, the GPS antenna will not have the top and bottom radome including the two screws and the rubber gasket. The label will be on the metal shield of the substrate assembly which will be the same size as the regular labels.

## RF Connectors/Cables Information

This page covers the construction and electrical characteristics of the Sumitomo [H-1.5D-SEXL] coaxial cable which is a part of the GPS antenna assembly. This is very similar to the 50 ohm RG174 cable type. Figure 4.10 shows the simplified views of this cable. Table 4.6 shows the key characteristics of this type of coaxial cable.

**Figure 4.10**

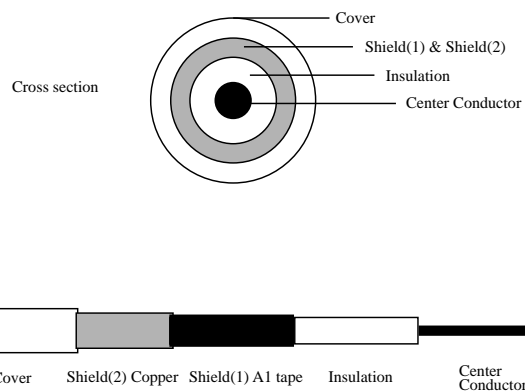

## Cable Structure & Performance

Table 4.6 Characteristics of coaxial cable

Items :		Dimension	Specification
Center	Material		Tinned Annealed Copper Wire
Conductor	Diameter	mm	0.54 (7 strands of 0.18 mm)
Insulation	Material	-	Irradiated Polyethylene
	Thickness	mm	0.54
	Outside Diameter	mm	1.62
Shield (1)	Material	-	Both side aluminum coated polyester tape
	Outside Diameter	mm	1.7
Shield (2)	Material	-	Tin coated copper wire braid
	Diameter of wire	mm	0.1
	Ends/Carriers	-	5/16
Cover	Material	-	Heat resistance black PVC
	Thickness	mm	0.39
	Outside Diameter	mm	3.0 +/- 0.20
Conductance		M/km	Less than 105
Non-Conductance		M/km	More than 1100
Capacitance		pF/m	110 (typ.) at 1 kHz
Impedance		$\Omega$	50 +/- 2
Operational Temperature Range		$^{\circ}\text{C}$	-40 to +105
Storable Temperature Range		$^{\circ}\text{C}$	-40 to +105
ATTENUATION		dB/m	Typical 0.73 at 900 MHz
		dB/m	Maximum 0.84 at 900 MHz
		dB/m	Typical 0.94 at 1500 MHz
		dB/m	Maximum 1.08 at 1500 MHz
		dB/m	Typical 1.10 at 1900 MHz
		dB/m	Maximum 1.21 at 1900 MHz

## Antenna Cable RF Connectors

The following RF Connectors are used to terminate cables of various Antenna models.

*Table 4.7 RF Connectors.*

Antenna Model #	Antenna Cable Connector Type	Manufacturer	Manufactureris Part #
GCNAC1232X	SMA	PHOENIX PELCO	20-0200-0670P
GCNAC1242X	GT-5	HIROSE	559-0078-2 559-0108-1
GCNAC1121X	BNC	M/A-Com	3201-7388-10 / 3231-7399-10
GCNAC1111X	OSX	PHOENIX PELCO	13-2800-0670

Contact the following Companies for information on mating connectors:

Phoenix / Pelco                   (800) 323-9562 or (630)595-2300  
M/A-Com                           (800) 366-2266 or (847) 776-0700  
Hirose                               (805) 522-7958  
LoDan Electronics               (847) 398-4995

## Environmental Tests

Provided below is an outline of the product durability and environmental specifications on the active GPS antenna assembly. Both magnet and mounting plate (bracket) style GPS antennas were qualified using the following test outline.

### *Durability Validation Tests*

Type of Test	Test Description
• Thermal cycling	Heat Cycle Test: Temp: -40 to +100 °C Power: 5V DC on/off cycling
• Thermal Shock	Thermal Shock Test: Temp.: -40 to +100 °C
• Humidity	Heat/Humidity cycle Test: Cycling temp. -10 to 60 °C at 65 to 95% R.H. Moisture Resistance Test: Constant temp. at 60 °C, 90% R.H.
• High Temp. Tests	High Temp. Storage Test: at +100°C . High Temp. Operating Test: Constant 5V DC at +100 °C
• Low Temp. Tests	Low Temp. Storage Test: at -40 °C. Low Temp. Operating Test: Constant 5V DC at -40 °C.
• Vibration Test	Random Vibration Test: Ref. spec. no.:MIL STD 810E ,Method 514.4. 7.7 G's RMS,1 hr per axis, all three axis.
• Mech. Shock Test	Mechanical Shock Test: Ref. spec. no.: MIL STD 810E, Method 516.4, Procedure I modified. 30 G's/18 ms for min. 100 G's/10 ms for min.
• Drop Test	Drop Test: Ref. spec. no.: MIL STD 810E, Method 516.4, Procedure IV modified. 1 meter drop onto concrete surface.
• Shipping Drop Test	Shipping Drop Test
• ESD Test	ESD Test: Test from 5 KV to 15 kV .

## Environmental Validation Tests

Type of Test	Test Description
• Salt Spray	Salt Atmosphere Test: Spray 5% NaCL solvent (at 35 °C).
• Ultraviolet Radiation	Weather Resistance Test: This is a standard JISD spec. Temp. of panel 63 °C
• Chemical Compatibility	Oil Resistant Test:
• Rain Test	Water Proofing Test: at 80 °C, spray water at 600 mm/hour for one hour

## Oncore Antenna Vibration Test Performance

Mechanical Vibration:

MIL SPEC 810E, Method 514.4: (Random Shock, 1 hour per axis)

Mechanical Shock:

Survival: 30G peak; 18ms duration - 500 pulses

100G peak, 10 ms duration - 10 pulses



## ANTENNA MODULE (ANT62301Ax)



*Figure 4.11: Antenna*

### ANTENNA MODULE CONNECTION AND MOUNTING

The Motorola low-profile antenna is specifically designed for use with the Oncore receiver. GPS signals are received by the antenna, amplified within the antenna assembly, and then relayed via cable to the Oncore receiver module for processing. The antenna is enclosed in a plastic housing which protects it from harsh environmental conditions.

#### Cable and Connector Requirements

The antenna module relays received GPS signals and receives power (5 Vdc @ 25 mA) from the receiver module via a single cable.

An RG-58 coaxial cable is recommended for proper connection of the antenna module to the receiver module. A female RF connector located in the base of the antenna module provides the necessary interface to the antenna's electrical circuitry. Note that for the Motorola antenna, the power loss along the cable should not exceed 14 dB at a frequency of 1575.42 MHz (GPS - L1). For RG-58 cables, the maximum cable length is restricted to 14 m to satisfy this 14 dB requirement.

RF connections between the antenna module and the receiver module are connected by cables having right angle subminiature snap-on connectors on both ends. The recommended suppliers for these RG-58 cable assemblies are:

- M/A-COM subminiature plugs; p/n: 5837-5006-13, and
- Phoenix Company subminiature plugs; p/n 13-2800-1200M.

## Cable and Connector Requirements (Continued)

If you are planning to use other suppliers for the plugs, they must mate to the corresponding subminiature jacks that are currently on the GPS receivers and GPS antennas. Please note, the recommended inner conductor wire for the RG58 cable should be the stranded type. For further details/reference, please see Motorola p/n: 3042451M01. The solid inner conductor type would probably work as good as the stranded one if the installer made sure to bend it to shape where it sits in the antenna base. For reference, the supplier name and their part numbers are:

- For GPS antennas: M/A-COM straight subminiature jack, p/n: 5862-5013-13,
- For GPS receivers: M/A-COM straight subminiature jack, p/n: 5862-5004-10 and M/A-COM right angle subminiature jack, p/n: 5864-5002-10, and Phoenix Company right angle subminiature jack; p/n: 13-3450-01N.

### Active Antenna Specifications

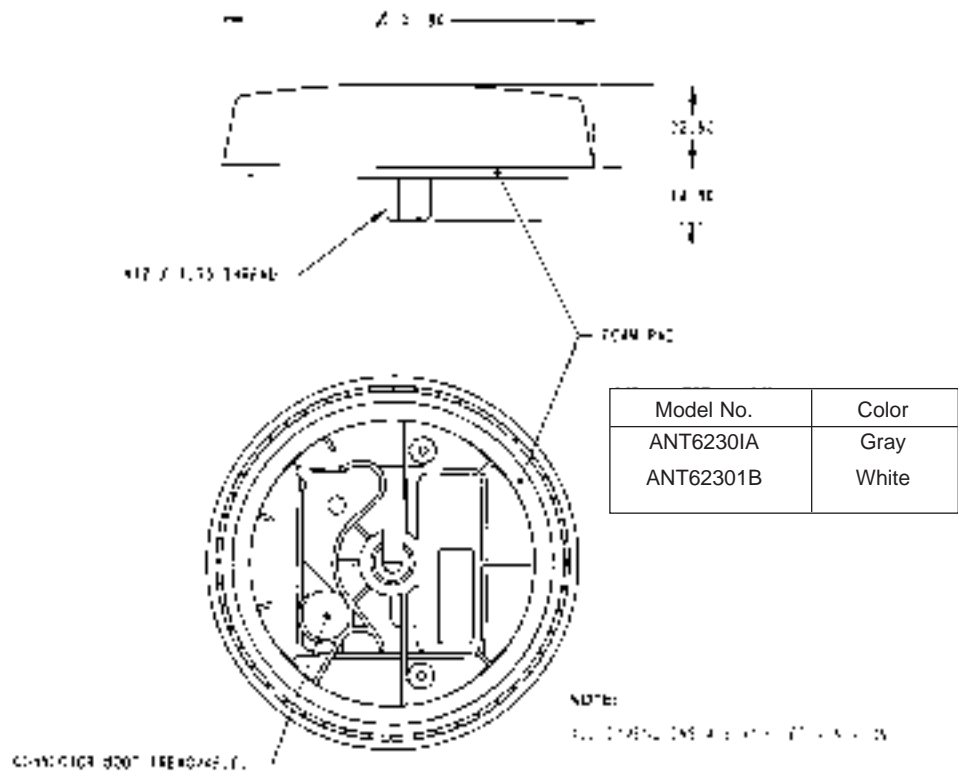

Figure 4.12

## GPS ANTENNA TECHNICAL CHARACTERISTICS

Table 4.8: ANT 62301 Ax

<b>General Characteristics</b>	Antenna Description	<ul style="list-style-type: none"> <li>Low profile active microstrip patch antenna encapsulated in a molded plastic housing</li> </ul>
	Operating Frequency	<ul style="list-style-type: none"> <li>L1 (1575.42 MHz)</li> </ul>
<b>Performance Characteristics</b>	Input Impedance	<ul style="list-style-type: none"> <li>50 Ohm</li> </ul>
	VSWR	<ul style="list-style-type: none"> <li>2:1 @ 1575.42 MHz (typical)</li> </ul>
	Bandwidth	<ul style="list-style-type: none"> <li>60 MHz (typical)</li> </ul>
	Polarization	<ul style="list-style-type: none"> <li>Right hand circular</li> </ul>
	Azimuth Coverage	<ul style="list-style-type: none"> <li>360 degrees</li> </ul>
	Elevation Coverage	<ul style="list-style-type: none"> <li>0 degrees to 90 degrees</li> </ul>
	Gain Characteristics	<ul style="list-style-type: none"> <li>+3 dBic minimum at zenith</li> <li>0 dBic minimum at 30 degrees elevation</li> <li>-6 dBic minimum at 0 degrees elevation</li> </ul>
	Filtering	<ul style="list-style-type: none"> <li>-30 dB at 1625 MHz (typical)</li> <li>-30 dB at 1475 MHz (typical)</li> </ul>
	LNA Gain	<ul style="list-style-type: none"> <li>22 dB (typical)</li> </ul>
	Noise Figure	<ul style="list-style-type: none"> <li>2.5 dB maximum</li> </ul>
	Burnout Protection	<ul style="list-style-type: none"> <li>Protected from damage by RF signals, when the power received by the antenna is no greater than +17dBm absolute maximum</li> </ul>
Dynamics	<ul style="list-style-type: none"> <li>Vibration: 7.7G per Military Standard 810E Method 514.4</li> <li>Shock: 30 g (18 ms sawtooth) Military Standard 810E Method 516.4</li> </ul>	
<b>Electrical Characteristics</b>	Power Requirements	<ul style="list-style-type: none"> <li>5 ± 0.25 Vdc 50 mVp-p ripple (maximum)</li> </ul>
	Power Consumption	<ul style="list-style-type: none"> <li>22mA (typical) @ 5 Vdc (50mA maximum)</li> </ul>
<b>Physical Characteristics</b>	Dimensions	<ul style="list-style-type: none"> <li>4.01 (dia.) x 0.89 in. [102 (dia.) x 22.6 mm]</li> </ul>
	Weight	<ul style="list-style-type: none"> <li>4.8 oz. (136.2 g)</li> </ul>
	Connectors	<ul style="list-style-type: none"> <li>90 degree OSX (subminiature snap-on)</li> </ul>
Antenna to Receiver Interconnection	<ul style="list-style-type: none"> <li>Single coaxial cable (-12 dB maximum loss at L1;1575.42 Mhz for Motorola GPS receivers)</li> </ul>	
<b>Environmental Characteristics</b>	Operating Temp.	<ul style="list-style-type: none"> <li>-40°C to +100°C</li> </ul>
	Storage Temp.	<ul style="list-style-type: none"> <li>-40°C to +100°C</li> </ul>
	Humidity	<ul style="list-style-type: none"> <li>95% noncondensing +30°C to +60°C</li> </ul>
	UV Radiation	<ul style="list-style-type: none"> <li>1000 hrs at +60°C as per ASTM G53-88</li> </ul>
	Salt Spray Test	<ul style="list-style-type: none"> <li>96 hrs at 35°C</li> </ul>
<b>Miscellaneous</b>	Optional Features	<ul style="list-style-type: none"> <li>Four mounting options: direct, post, lip, magnetic</li> </ul>

## Antenna Gain Pattern

The sensitivity of an antenna as a function of elevation angle is represented by the gain pattern. Some directions are much more appropriate for signal reception than others, so the gain characteristics of an antenna play a significant role in the antenna's overall performance.

A cross-sectional view of the antenna gain pattern along a fixed azimuth (in a vertical cut) is displayed in the following figure. The gain pattern clearly indicates that the antenna is designed for full, upper hemispherical coverage, with the gain diminishing at low elevations. This cross-section is representative of any vertical cross-section over a 0 to 360 degree azimuth range and thus, the 3-dimensional gain pattern is a symmetric spheroidal surface. It is important to note that this gain pattern varies in elevation angle, but not in horizontal azimuth. This design is well-suited for many GPS applications, accommodating full sky coverage above the local horizon and minimizing ground-reflected multipath effects.

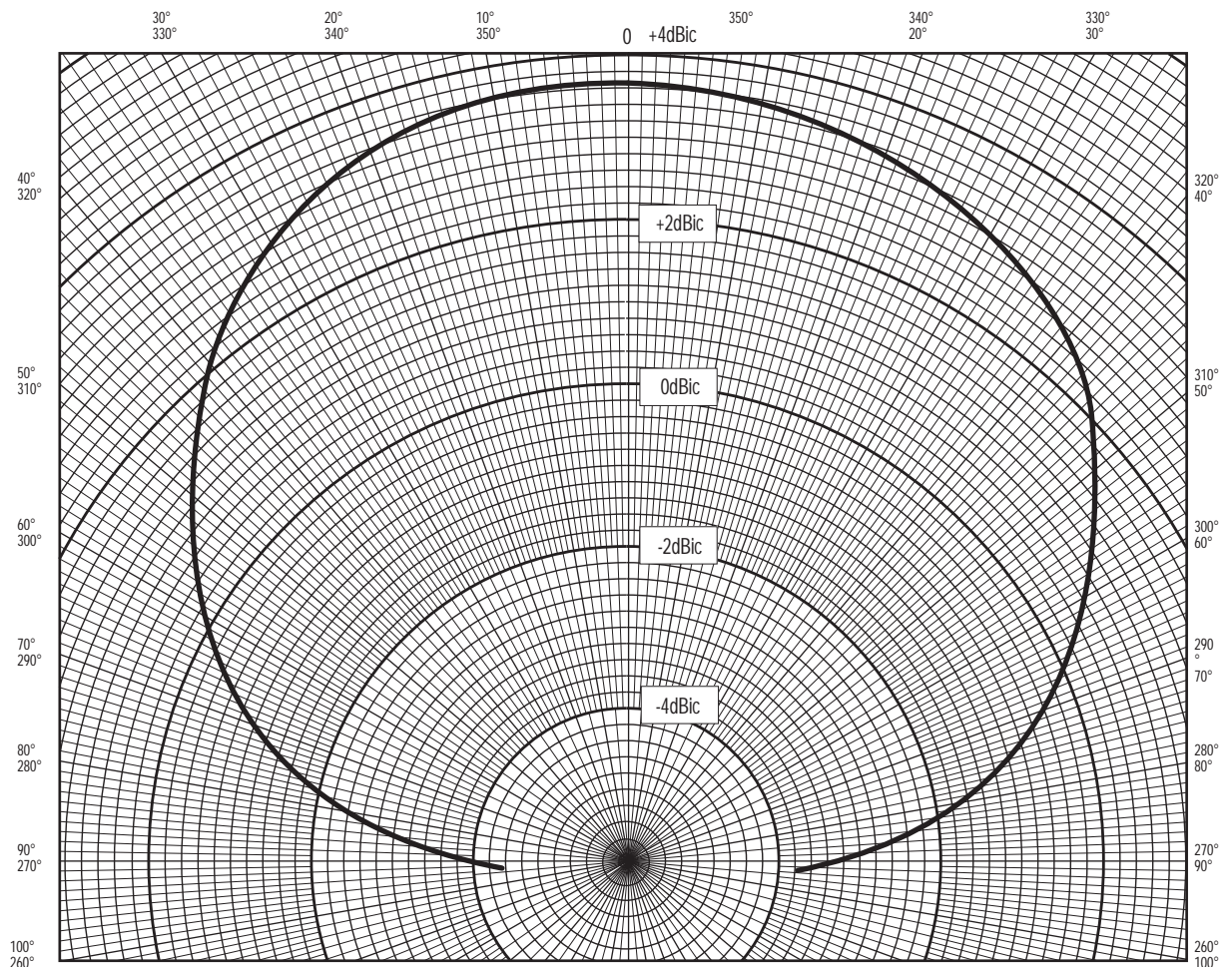

*Figure 4.13: Typical Antenna Gain Pattern For ANT 62301xx*

## Mounting

The following five different antenna mount options are available for the antenna module:

- Direct Mount Kit.
- Lip Mount Kit.
- Magnet Mount Kit.
- Post Mount Kit.
- Marine Mount.

Refer to the following table for recommended antenna installation torques.

*Table 4.9 Recommended Installation Torques*

Assemble and/or mount GPS Antenna Model # ANT6301A1 (grey) ANT62301B1 (white) Model # ANT6301A2 (grey) ANT62301B2 (white)		
Direct Mount	Model No. MNT62311A1:	<b>12 to 15 in-lb</b>
Post Mount	Model No. MNT62312A1:	<b>12 to 15 in-lb</b>
Lip Mount	Model No. MNT62313A1:	<b>10 to 12 in-lb</b>
Magnet Mount	Model No. MNT62314A1:	<b>10 to 12 in-lb</b>
Marine Mount	Model No. MNT62315B1:	<b>12 to 15 in-lb</b>

**Notes:** 1. For all antennas marked with Model Years 92 and 93, the recommended torque should not exceed 10 in-lb. for the different mounting versions.

2. English to metric - torque conversion:

- 10 in-lb = 1.13 N-m = 0.115 kg-m
- 12 in-lb = 1.35 N-m = 0.138 kg-m
- 15 in-lb = 1.69 N-m = 0.173 kg-m

## Antenna Module Mounting (Continued)

### Direct Mount Kit Installation

The direct mount accommodates applications requiring rigid, surface mounting.

Perform the following steps to install the direct mount kit:

1. Drill a 20 mm hole through the deck plane where you will place the antenna.
2. Attach the antenna cable connector to the mating connector on the antenna module base.

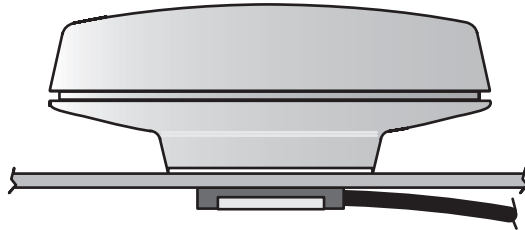

*Figure 4.14: Direct Mounted Antenna Module*

3. Insert the connector boot over the cable connection and into the circular boot socket.
4. Route the antenna cable along the strain relief track located in the base of the antenna module (see Figure 4.15).
5. Route the antenna cable through the hollow slot in the antenna module's threaded stem.
6. Remove the peel-off liner from the outer gasket and attach the gasket to the bottom of the mounting shroud.
7. Insert the threaded stem through the mounting shroud, outer gasket and deck plane.

**NOTE:** The following information applies to the new models numbers MNT62311A2 and MNT62311B2. All other model numbers refer to the "Recommended Installation Torques" Table 4.9.

8. Install and tighten the cable retaining nut clockwise to the threaded stem of the antenna module until an audible "CLICK" sound is identified. After that tighten an additional 3/4 turn clockwise. If you turn too much, you will hear another "CLICK" noise indicating that too much torque was applied. Again, to apply proper torque tighten an additional 3/4 turn. This setting gives about 8/10 in.lbs. average installation torque.

# Direct Mount Kit Installation (Continued)

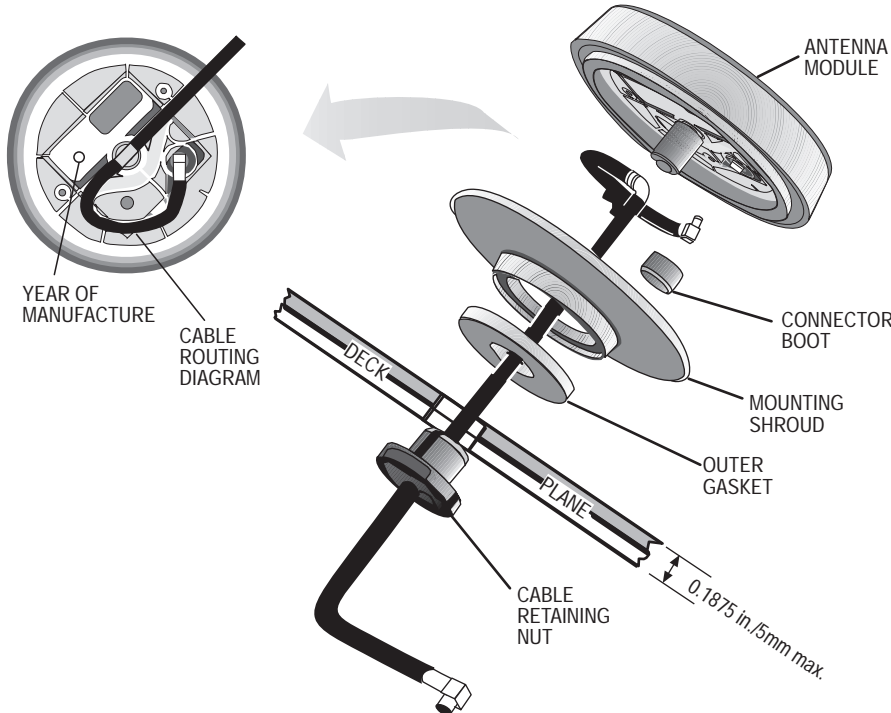

Figure 4.15: Direct Mount Kit Assembly

**NOTE:** For low-profile cable mounting, route the antenna interface cable through the side slot in the cable retaining nut.

## Antenna Module Mounting (Continued)

### Lip Mount Kit Installation

The lip mount allows for antenna placement along the edge of a deck plane (3.2 mm maximum thickness), such as the trunk lid of an automobile.

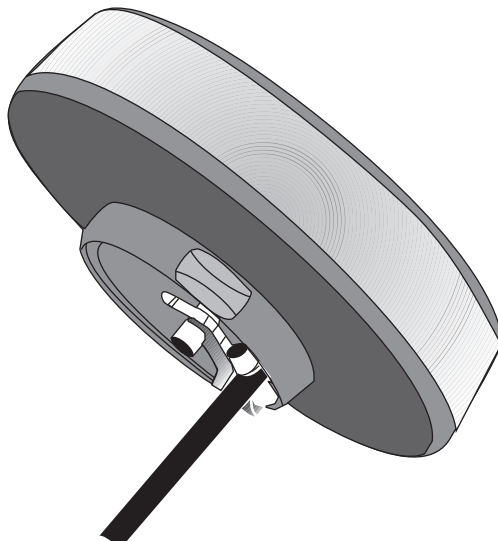

*Figure 4.16: Lip Mounted Antenna Module*

Perform the following steps to install the lip mount kit.

1. Attach the antenna cable connector to the mating connector at the antenna module base.
2. Insert the connector boot over the cable connection and into the circular boot socket.
3. Route the antenna cable along the strain relief track located in the bottom of the antenna module (see Figure 4.17).
4. Fit the mounting shroud to the antenna module.
5. Route the antenna cable through the side slot in the middle of the mounting shroud base.
6. Place the lip bracket over the threaded stem of the antenna module and pass the cable through the lip bracket cable notch.
7. Tighten the panel nut onto the threaded stem, securing the entire assembly. A 15 mm 6 point socket is recommended. Refer to Table 4.9 for torque requirements.
8. Remove the peel-off liner from lip bracket pad and adhere the pad to the lip bracket covering the panel nut.
9. Clip the lip bracket assembly to the selected antenna deck plane (3.2 mm maximum).
10. Tighten the entire assembly to the deck plane by tightening the set screws. The recommended torque for the set screws is 4 in. lbs. each. For any reason, do not go above 6 in. lbs. torque You'll need a 2.5mm hex head allen wrench that will tighten these set screws.



# Antenna Module Mounting (Continued)

# Lip Mount Kit Installation (Continued)

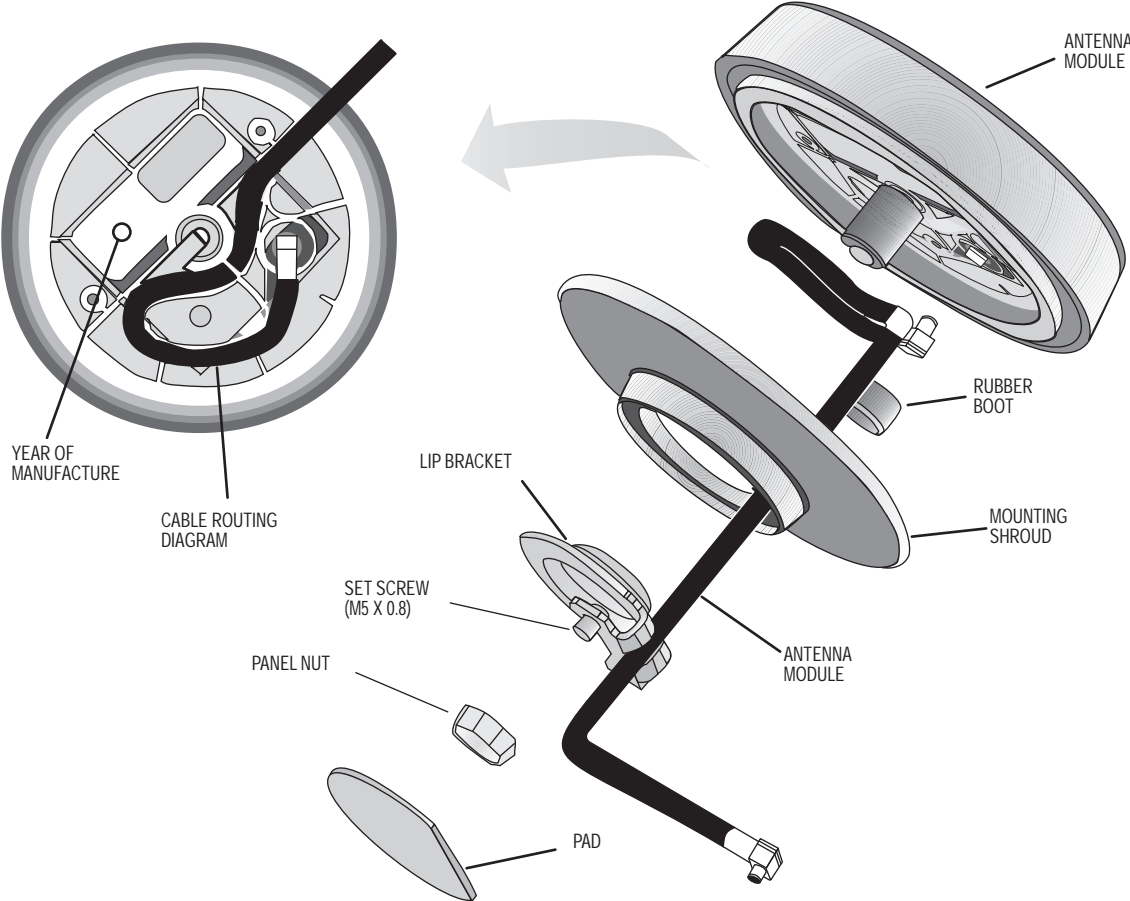

Figure 4.17: Lip Mount Kit Assembly

## Antenna Module Mounting (Continued)

### Magnet Mount Kit Installation

The magnet mount allows you to mount the antenna module on a flat metal surface without the need to drill mounting holes.

An adhesive-backed insulator is placed over the magnet at the base of the shroud to prevent surface scratching.

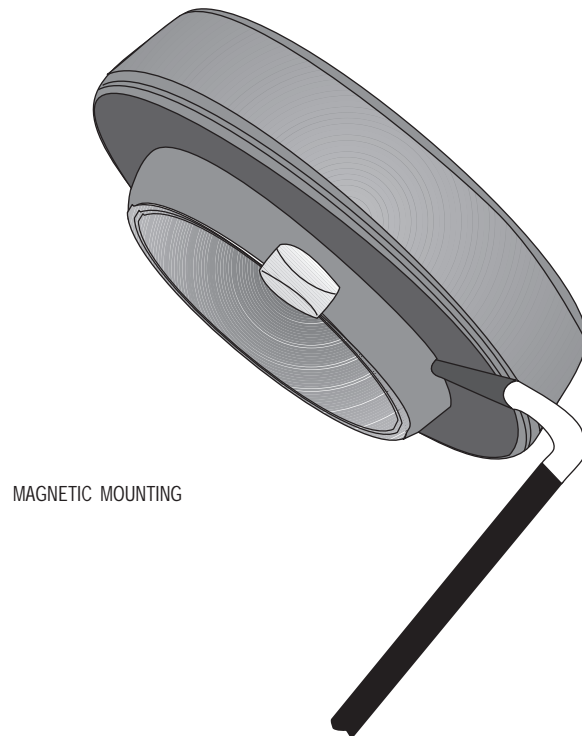

*Figure 4.18: Magnet Mounted Antenna Module*

Perform the following steps to assemble the magnet mount kit.

1. Attach the antenna cable connector to the mating connector at the antenna module base.
2. Insert the connector boot over the cable connection and into the circular boot socket (see Figure 4.19).
3. Route the antenna cable along the strain relief track located at the base of the antenna module.
4. Insert the antenna module into the mounting shroud. Align the shroud's cable exit slot over the cable.
5. Insert the magnet into the shroud such that the magnetic side faces outward.
6. Tighten the panel nut onto the threaded stem, securing the entire assembly. Refer to Table 4.9 for torque requirements.
7. Remove the peel-off liner from the insulator and adhere the protective insulator over the magnetic surface at the base of the shroud.

Antenna Module  
Mounting (Continued)

Magnet Mount Kit Installation (Continued)

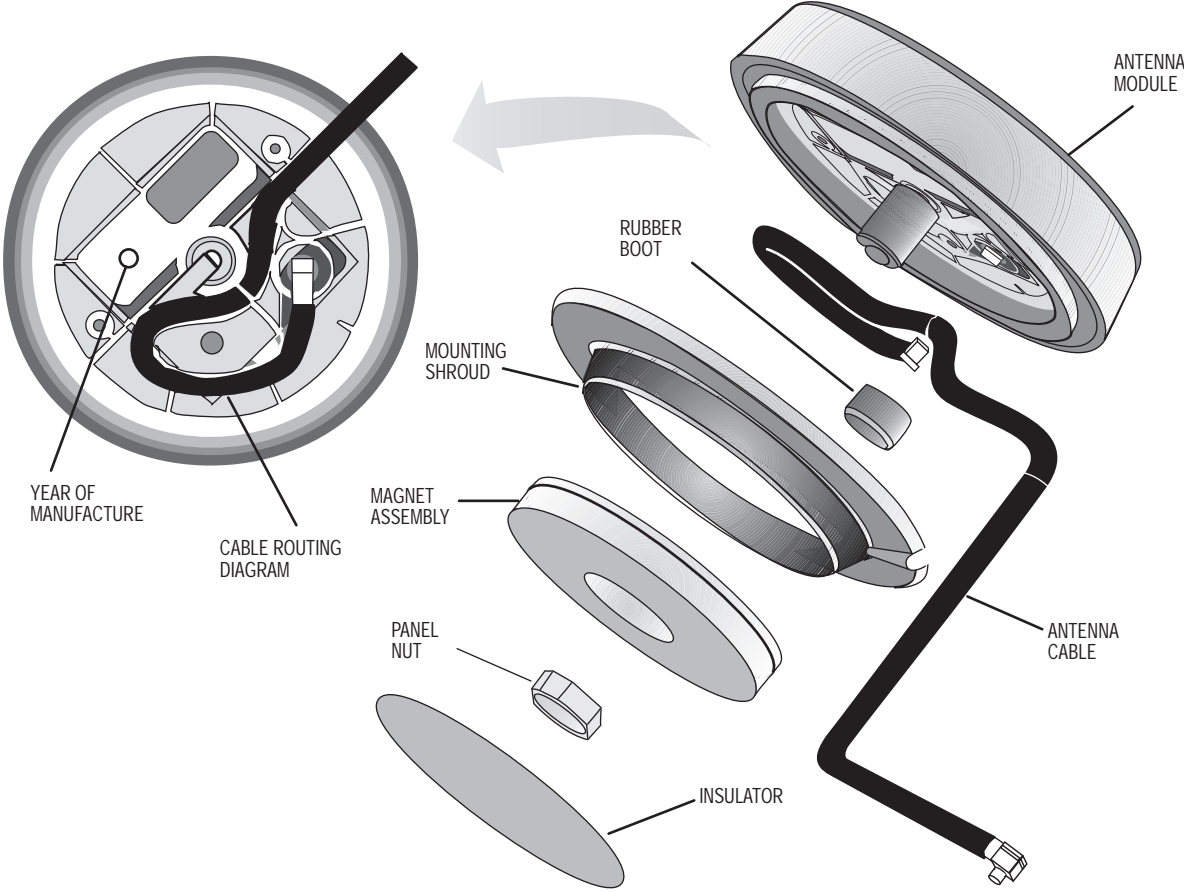
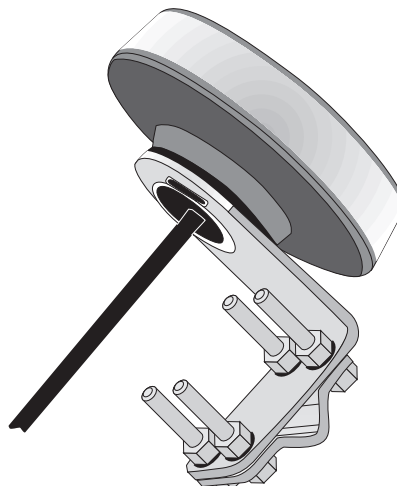

Figure 4.19: Magnet Mount Kit Assembly

## Antenna Module Mounting (Continued)

### Post Mount Kit Installation

The post mount allows you to mount the antenna module onto a vertical or horizontal post or bar with a maximum diameter of 30 mm (such as the support arm of a truck's external side mirror).



*Figure 4.20: Post Mount Antenna Module*

Perform the following steps to assemble the post mount kit.

1. Attach the antenna cable connector to the mating connector on the antenna module.
2. Insert the connector boot over the antenna cable connector and into the circular boot socket.
3. Route the antenna cable along the strain relief track located in the base of the antenna module.
4. Route the antenna cable through the hollow slot in the antenna module's threaded stem.
5. Remove the peel-off liner from the outer gasket and attach to the bottom of the shroud.
6. Insert the threaded stem through the mounting shroud, outer gasket, and post bracket.

**NOTE:** The following information applies to the new models numbers MNT62311A2 and MNT62311B2. All other model numbers refer to the "Recommended Installation Torques" Table 4.9.

7. Install and tighten the cable retaining nut clockwise to the threaded stem of the antenna module until an audible "CLICK" sound is identified. After that tighten an additional 3/4 turn clockwise. If you turn too much, you will hear another "CLICK" noise indicating that too much torque was applied. Again, to apply proper torque tighten an additional 3/4 turn. This setting gives about 8/10 in.lbs. average installation torque.

## Antenna Module Mounting (Continued)

### Post Mount Kit Installation (Continued)

8. Attach the post to the post bracket with the bolts, post clamp, lock washers, and nuts.

NOTE: The post bracket can support a vertical or horizontal post by rotating the post clamp. For low profile mounting, route the cable through the side slot in the cable retaining nut.

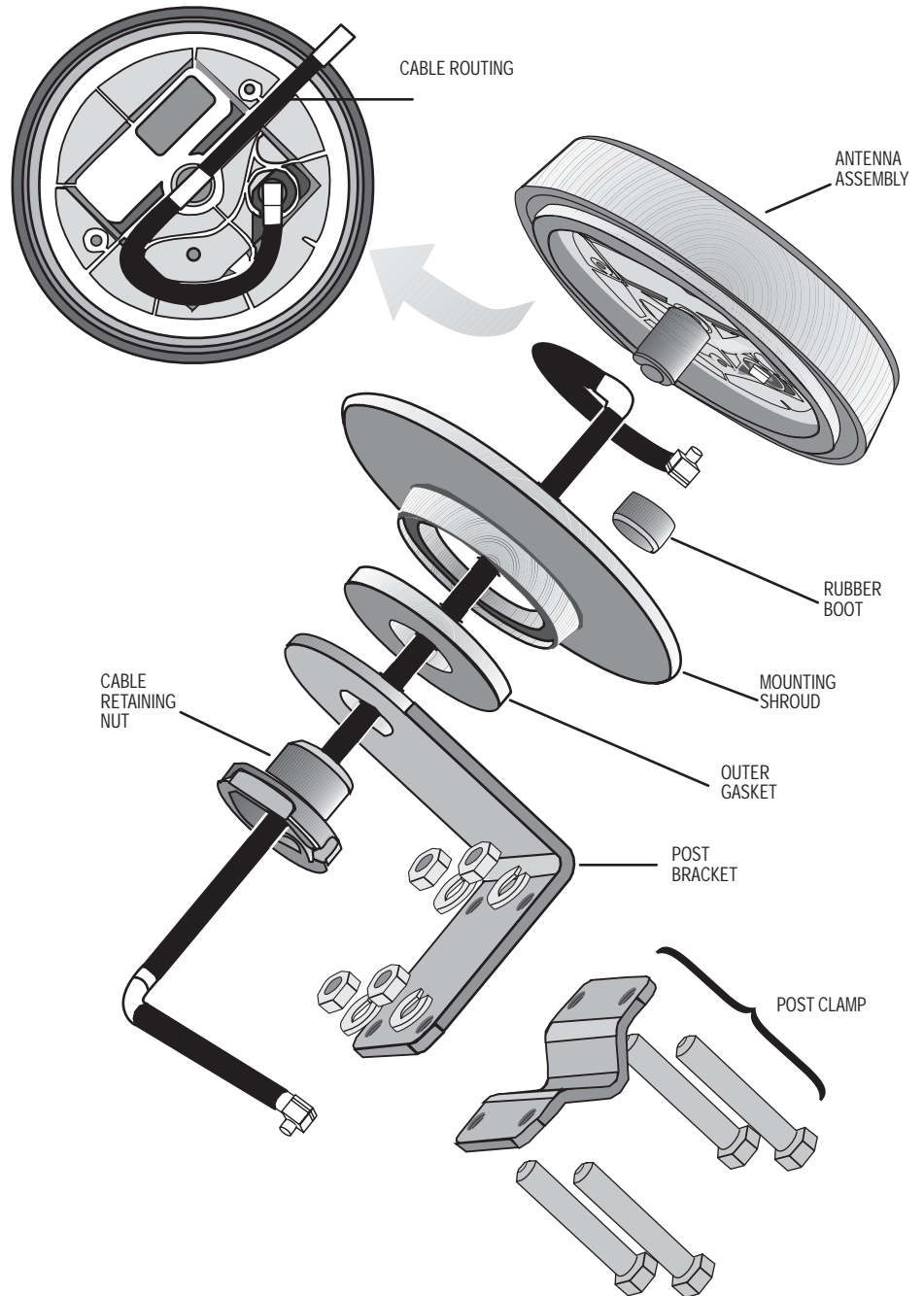

Figure 4.21: Post Mount Kit Assembly

## Antenna Module Mounting (Continued)

### Marine Mount Installation

The Marine Mount allows you to mount the antenna module onto a vertical mounting post. (Such as posts found on boats.)

Figure 4.22: Marine Mount Module

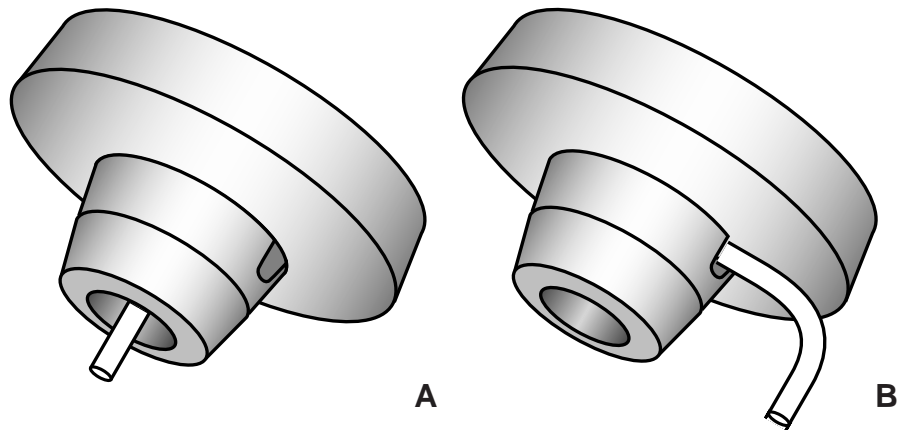

Perform the following steps to assemble the Marine Mount Kit

1. Attach the antenna cable connector to the mating connector on the antenna module.
2. Insert the connector boot over the antenna cable connector.
3. Route the antenna cable along the strain relief track located in the back of antenna module.
4. Assemble the collar onto the mounting shroud.
5. There are two ways to route the antenna cable:
  - fig. 13A. Shows the cable routed through the mounting post (i.e.) through the adapter
  - fig. 13B. Shows the cable routed through side of the collar

**NOTE:** The following information applies to the new model number MNT62315B2. All other model numbers refer to the “Recommended Installation Torques” Table 4.9.

6. Turn the antenna assembly clockwise onto the Marine Mount Post until an audible “CLICK” sound is identified. Tighten an additional 3/4 turn to obtain proper setting. If you tighten too much you will hear another audible “CLICK” indicating that too much torque was applied. Again, apply a 3/4 turn to obtain proper setting. This setting gives about 8/10 in.lbs. average torque which should be sufficient for many applications.

## Antenna Module Mounting (Continued)

## Marine Mount Installation (Continued)

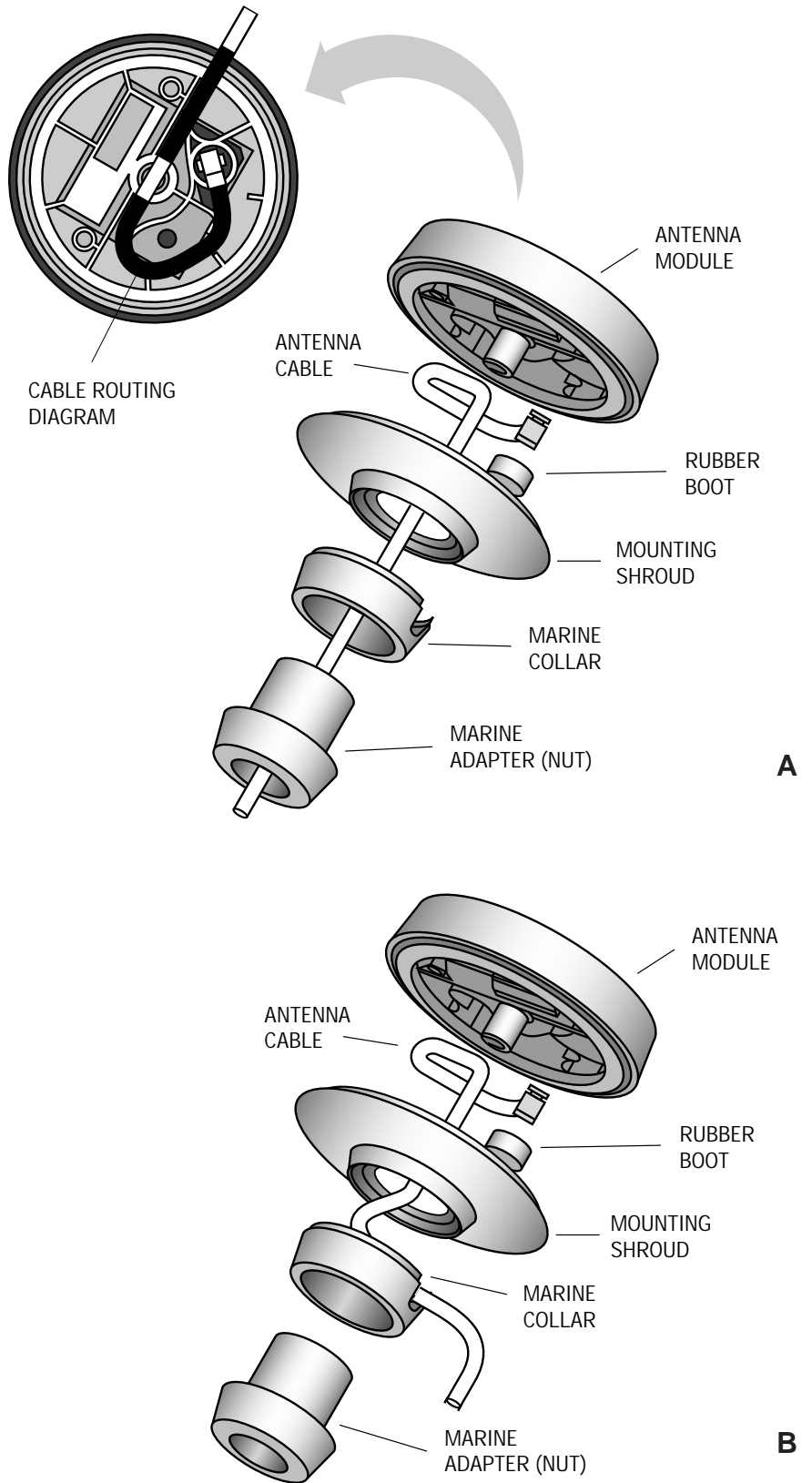

Figure 4.23: Marine Mount Kit Assembly